



RE+BUS

RENOVATING BUILDINGS SUSTAINABLY

WP 3 - FACADEUDVIKLING

Følgegruppemøde, T1

6. Juni 2019

Vi vil sikre...

At renoveringsløsningen for facaden, giver bedre indeklima og øget merværdi.

At løsningen kan udføres **udefra og ind** med en **letforståelig beboerinddragelse** og markant **færre gener for beboere under udførelse**.

At denne gevinst ligeledes opnås når det givne projekt også **indeholder andre renoverings-tiltag** (bad, køkkener, tilgængelighed etc.).

An aerial photograph of a university campus, overlaid with a semi-transparent green filter. The campus features numerous long, light-colored dormitory-style buildings arranged in a grid-like pattern. There are several green fields, including what appears to be a baseball field on the right side. A road with a roundabout is visible on the left, and another road curves around the bottom of the campus. The text "REBUS' PROCES" is written in a white, sans-serif font across the middle-left portion of the image.

REBUS' PROCES

RE+BUS



Registrering

Indledende dialog

Myndigheder

Beboerdialog

Aftale

Opførelse

Ibrugtagning



REBUS ønsker:

- en mere effektiv renoveringsproces for at opnå flere renoveringer af højere kvalitet
- tidlig etablering af beslutningsgrundlag mht. pris og performance
- transparent dialog mellem interessenter og generel risikominimering
- en løsning, der tillader renovering med markant færre gener for beboere
- gennem industrialisering at sikre mindre spild, mindre ressourceforbrug og højere produktivitet

RE+BUS



Registrering

Indledende dialog

Myndigheder

Beboerdialog

Aftale

Opførelse

Ibrugtagning



Hurtig etablering af datagrundlag

Registrering

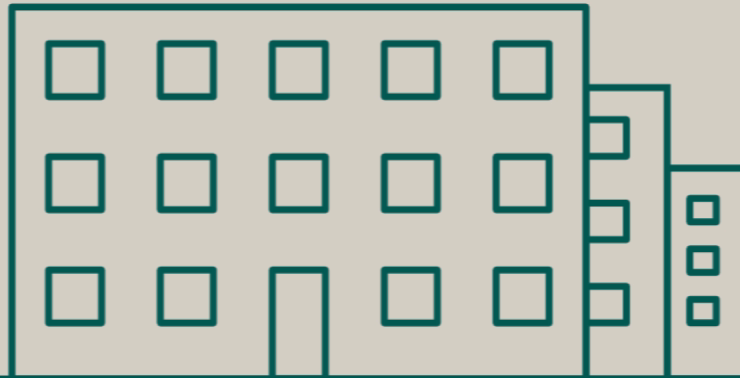



Hurtig etablering af datagrundlag

Registrering



RE+BUS



Registrering

Indledende dialog

Myndigheder

Beboerdialog

Aftale

Opførelse

Ibrugtagning



Indledende dialog

Klart og hurtigt beslutningsgrundlag via konfigurator

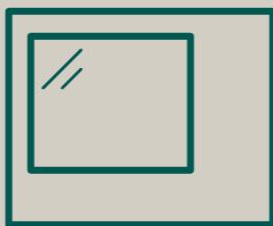



Indledende dialog

Klart og hurtigt beslutningsgrundlag via konfigurator

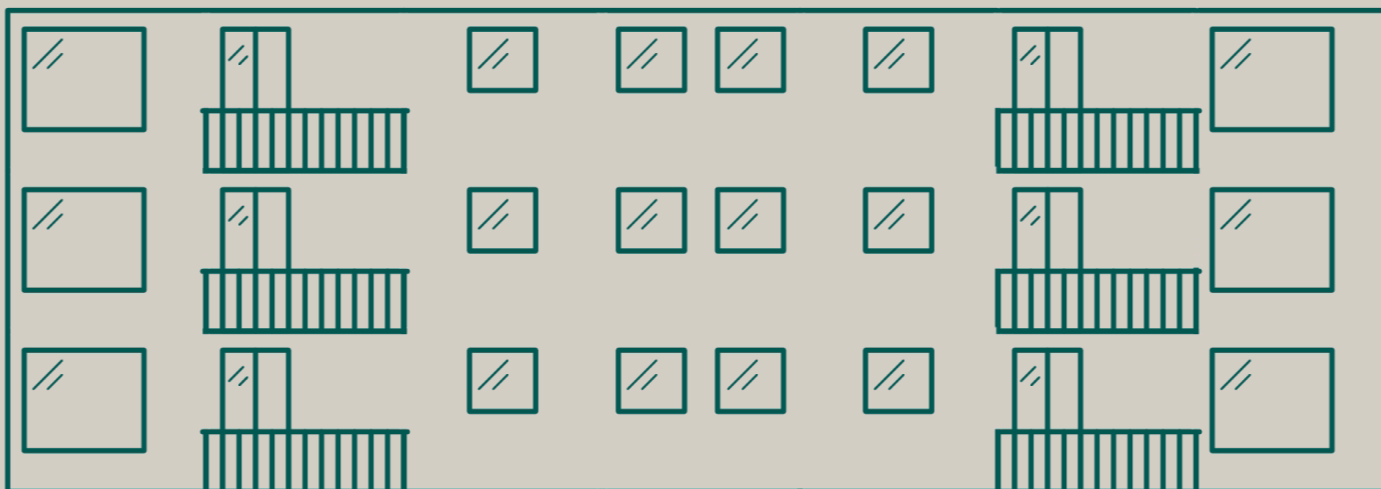

RE+BUS



Registrering

Indledende dialog

Myndigheder

Beboerdialog

Aftale

Opførelse

Ibrugtagning



Transparens i valg og let forventningsafstemning

Beboerdialog

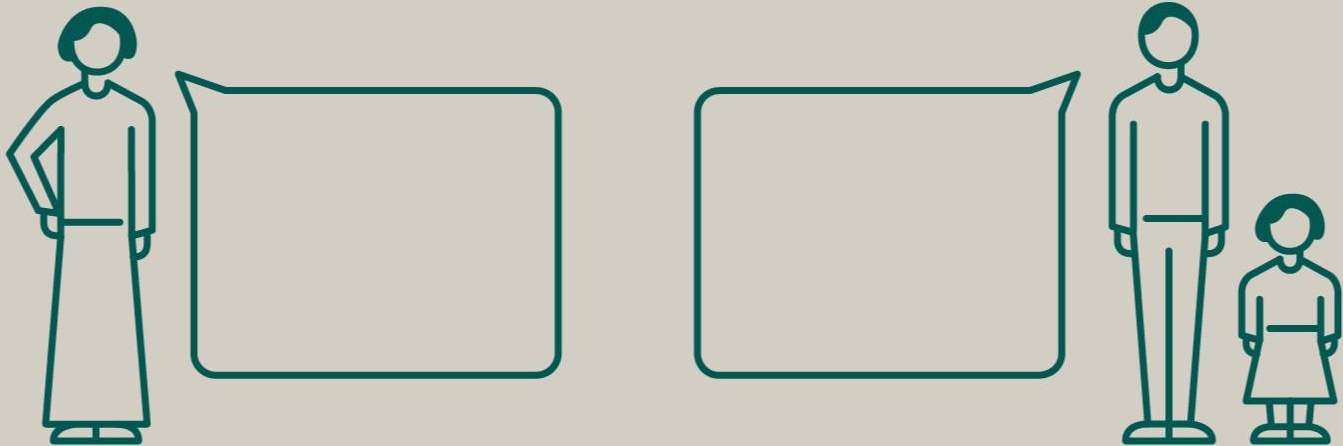



Transparens i valg og let forventningsafstemning

Beboerdialog



RE+BUS



Registrering

Indledende dialog

Myndigheder

Beboerdialog

Aftale

Opførelse

Ibrugtagning



Typisk renoveringsproces

Opførelse

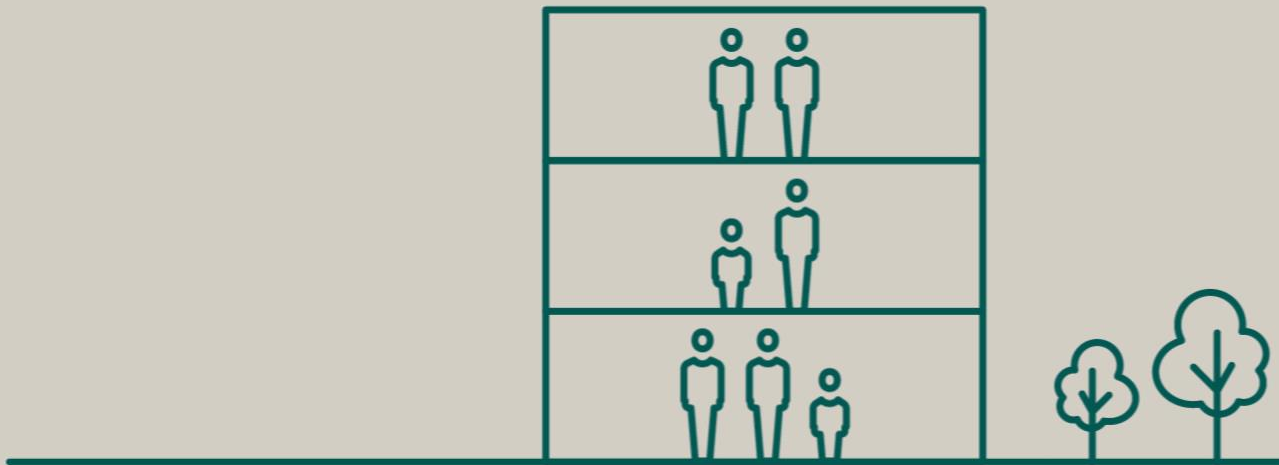



Typisk renoveringsproces

Opførelse

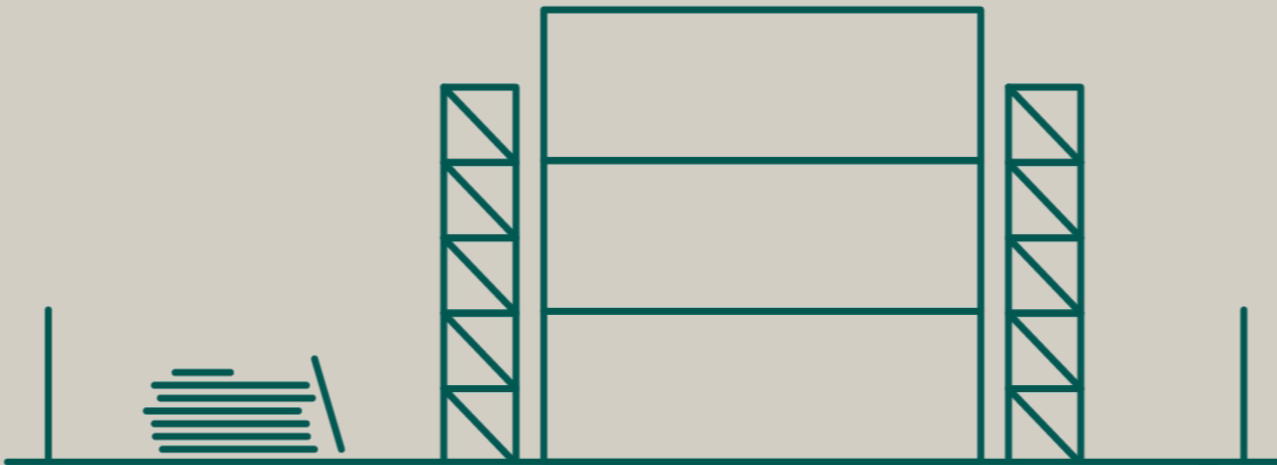



Hurtig udførelse, mindre genhusning & færre beboeregener

Opførelse

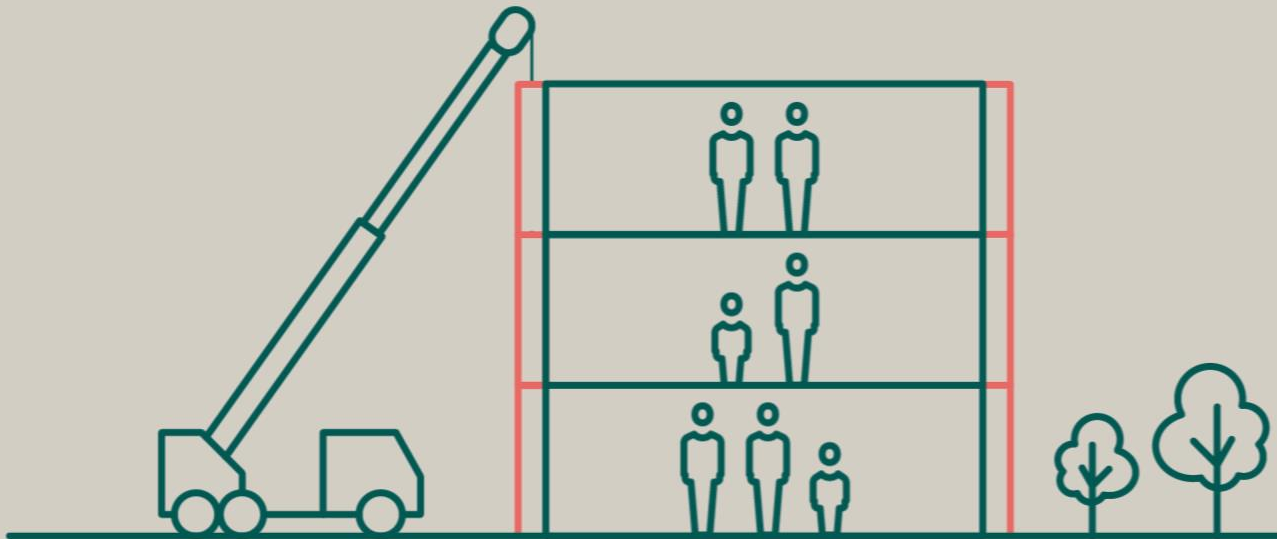

RE+BUS



Registrering

Indledende dialog

Myndigheder

Beboerdialog

Aftale

Opførelse

Ibrugtagning



Dokumenterbar kvalitet

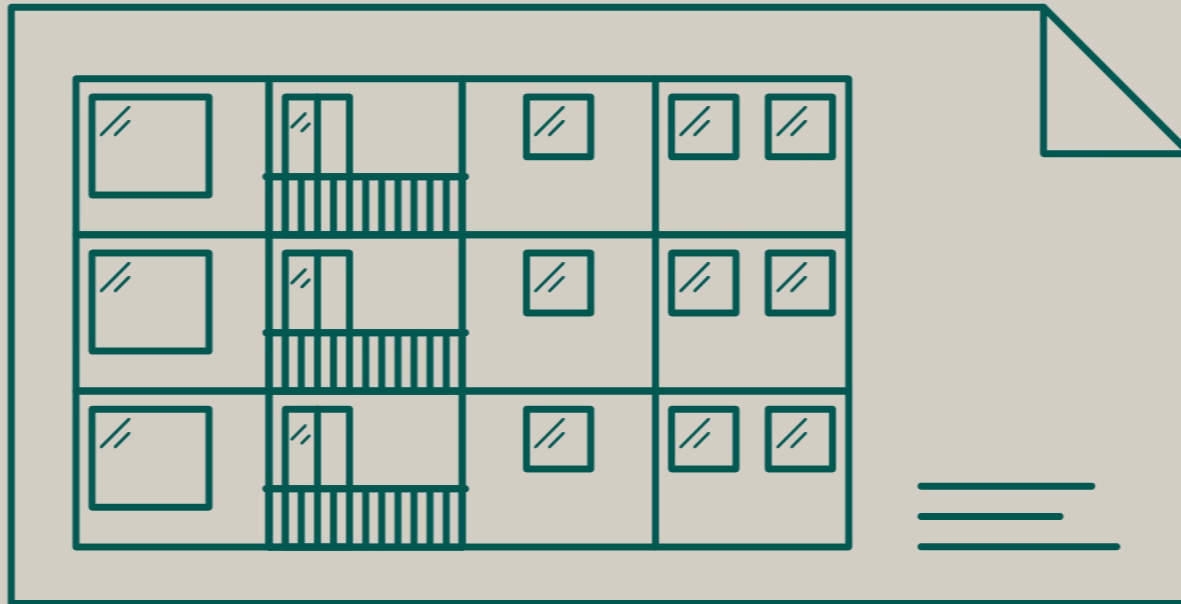



Dokumenterbar kvalitet

Ibrugtagning

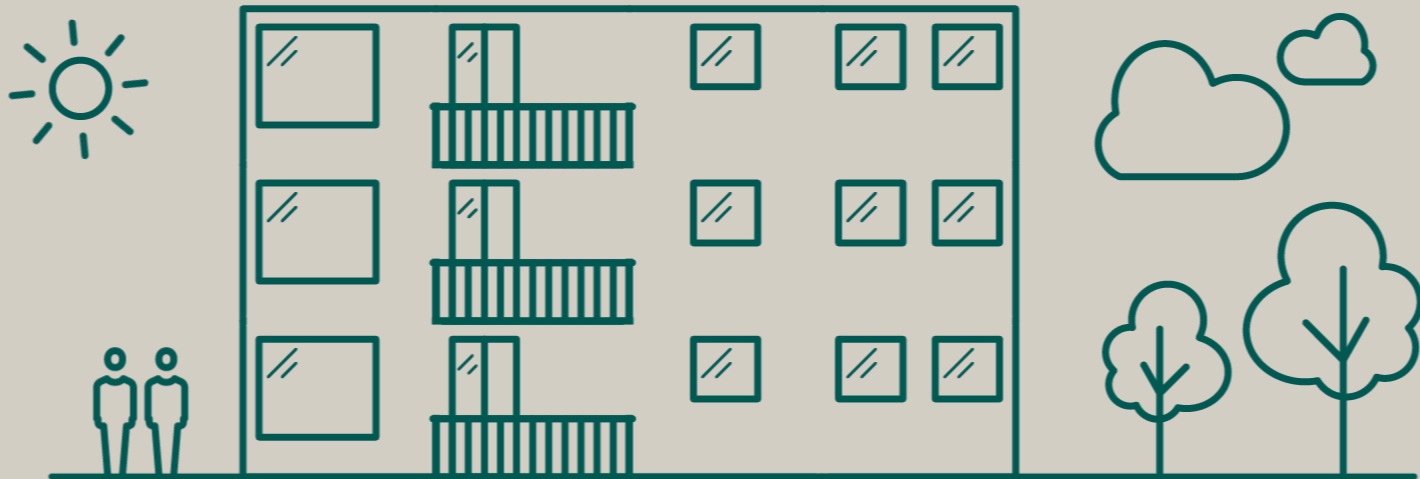

FACADEKONCEPTER

An aerial photograph of a modern university campus. The central focus is a large, multi-story building with a dark facade and numerous windows, surrounded by a green courtyard. The courtyard features a paved walkway, several trees, a playground with a slide, and a small structure. In the background, other campus buildings and a city skyline are visible under a clear sky. The text 'FACADEKONCEPTER' is overlaid in white on the left side of the image.

Moduler

- Vi vil kunne bygge uden på eksisterende facade med tværgående installationer integreret
- Præfab elementer spænder fra tværvæg til tværvæg



Konfigurerbar løsning

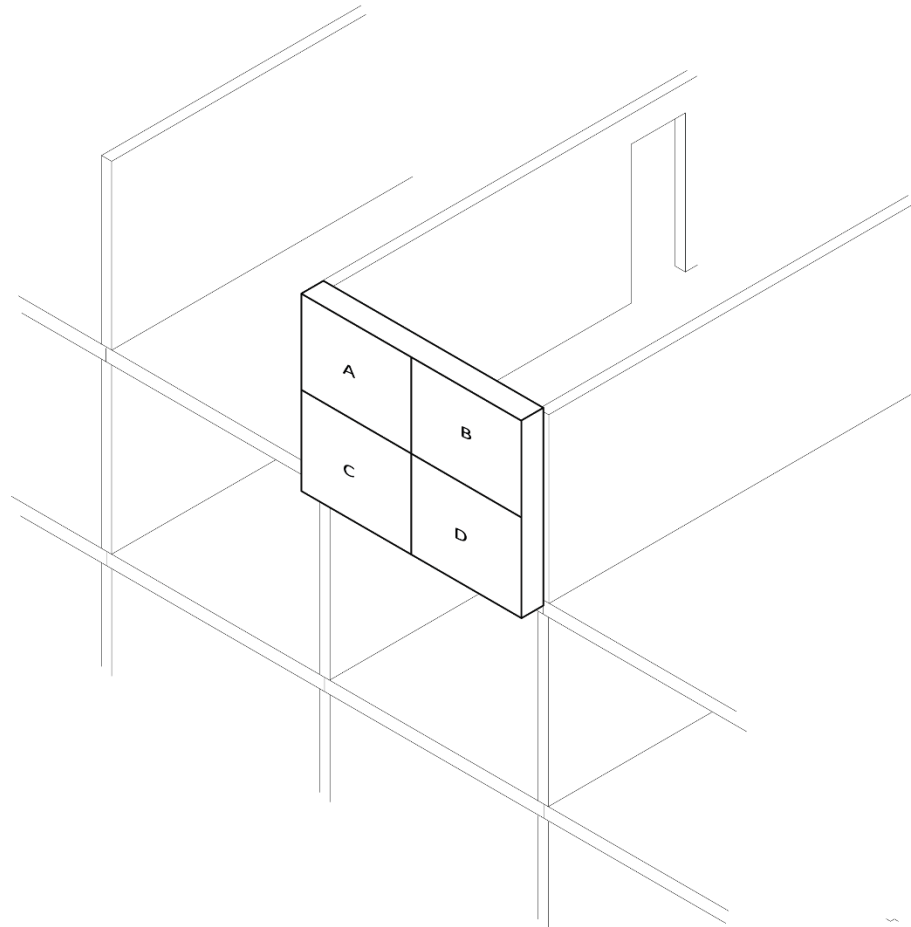

Katalog

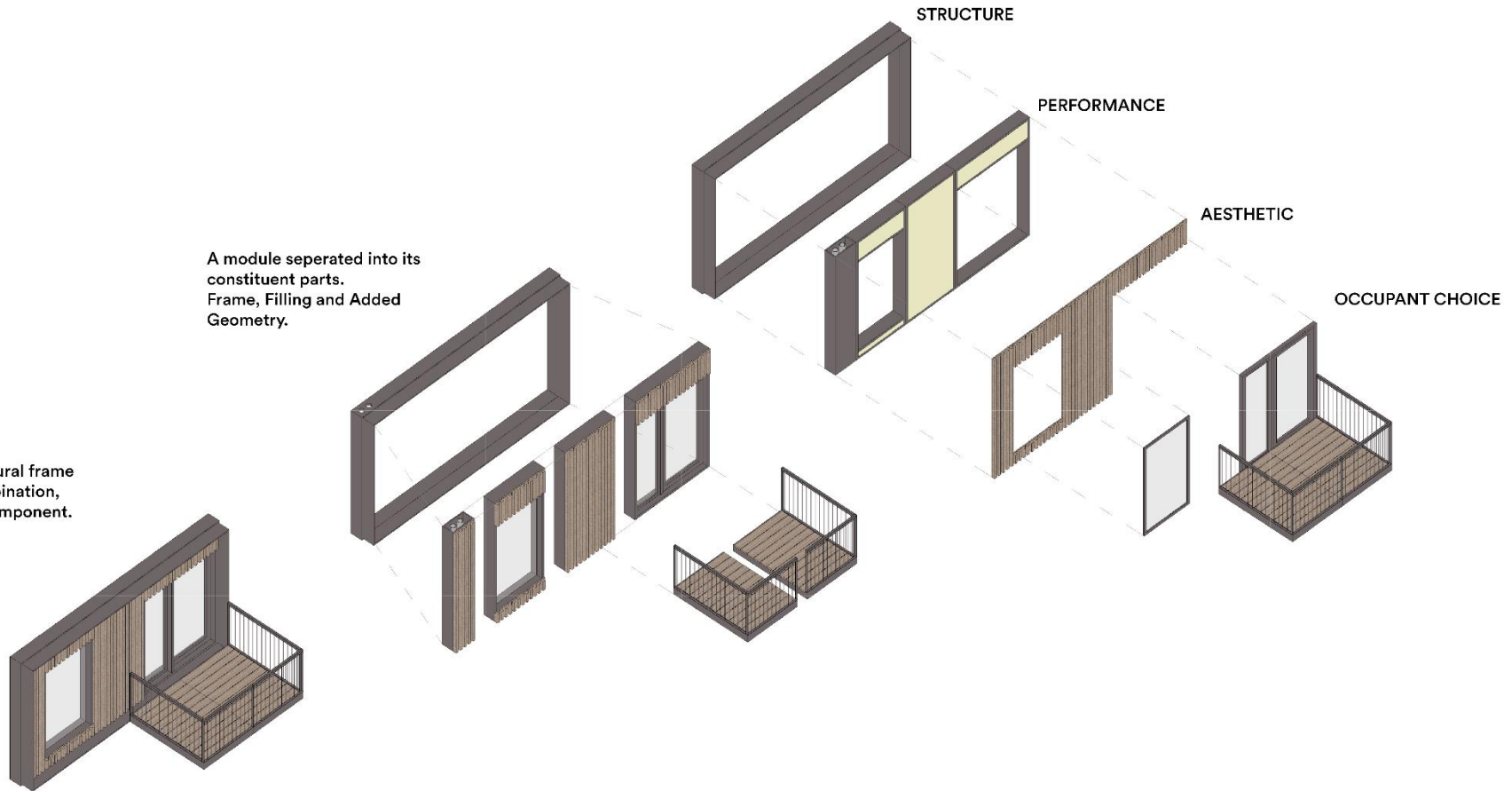

Katalog

BLOCKS

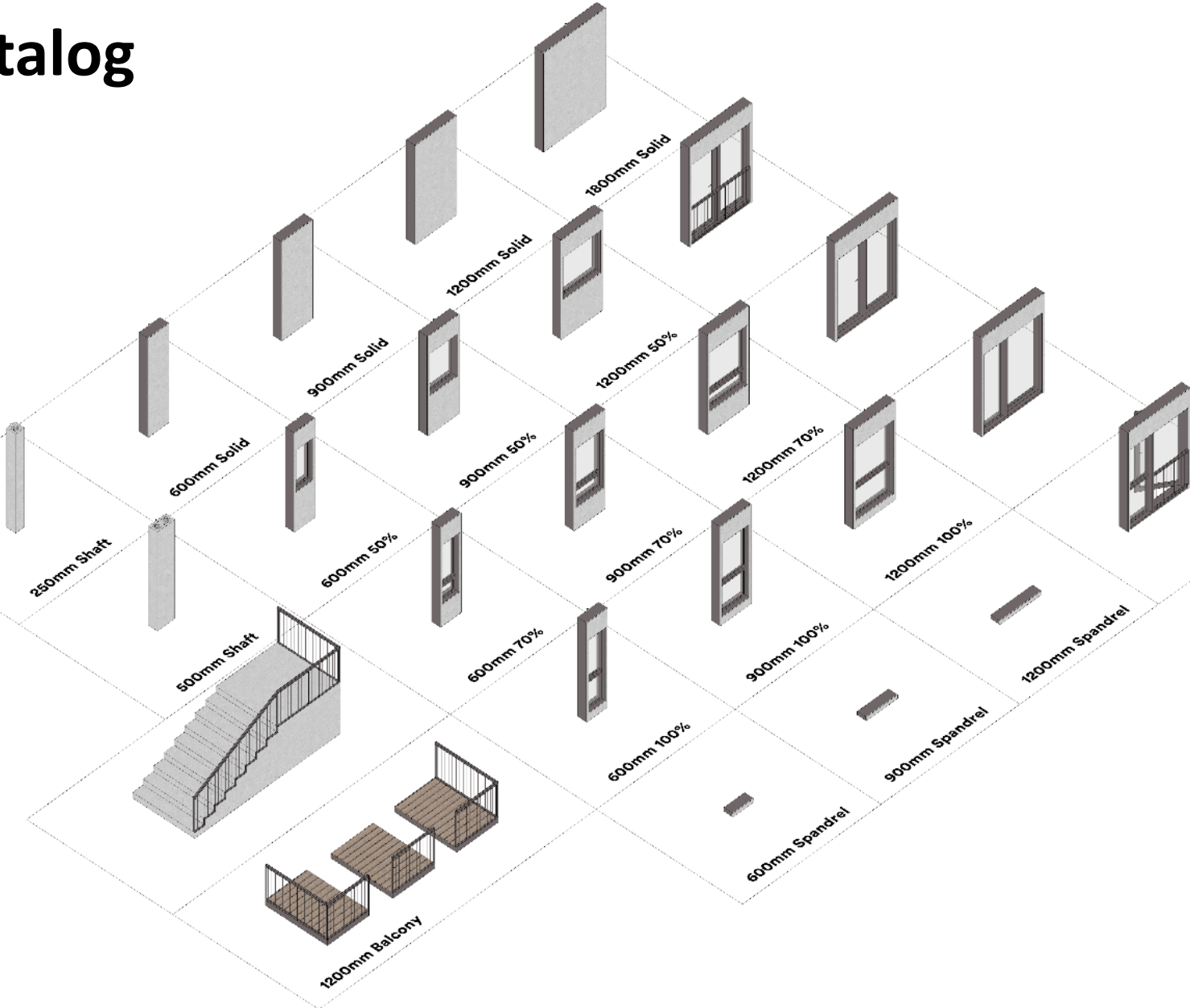

Katalog

FILLING

FAÇADE CLADDING // MATERIALITY

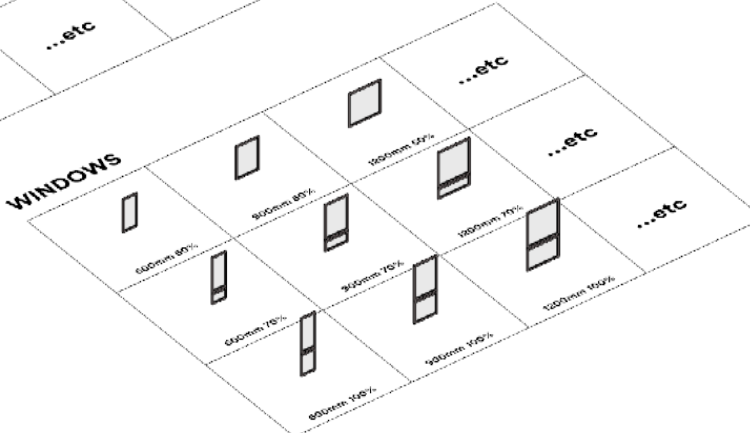
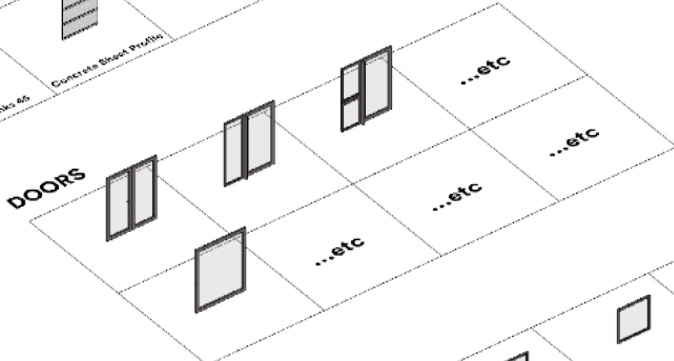
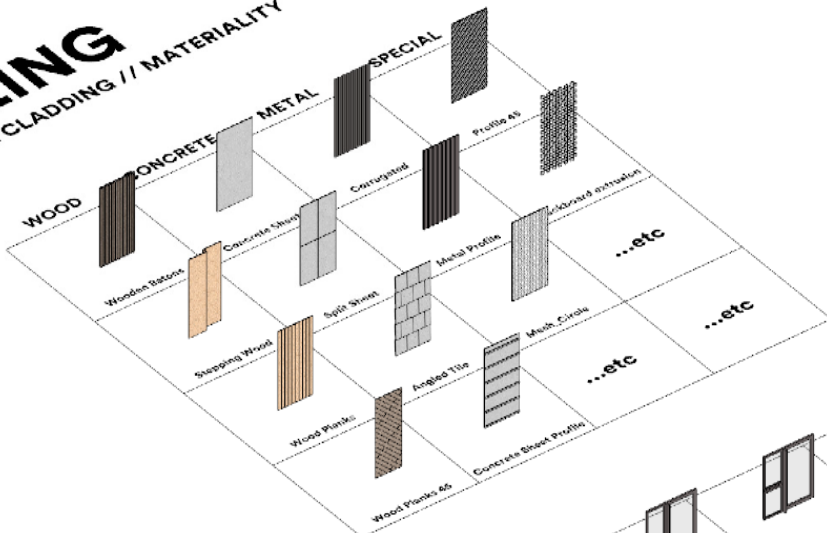

Katalog – mulighed for differentiering

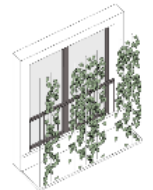
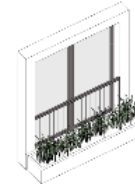
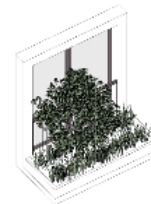
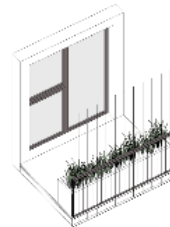
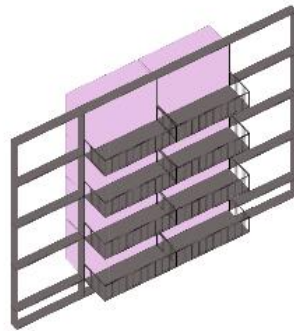
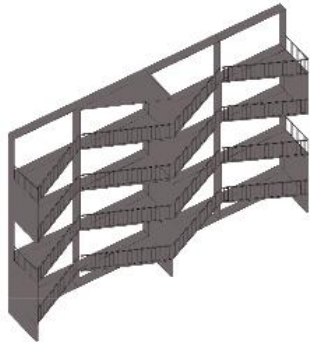
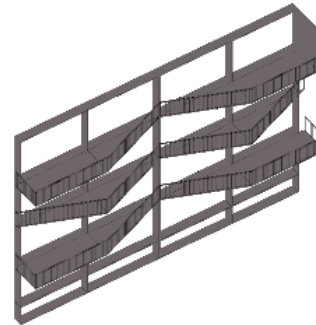
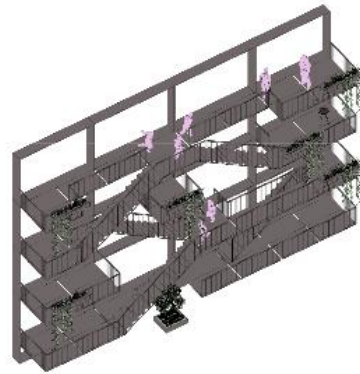
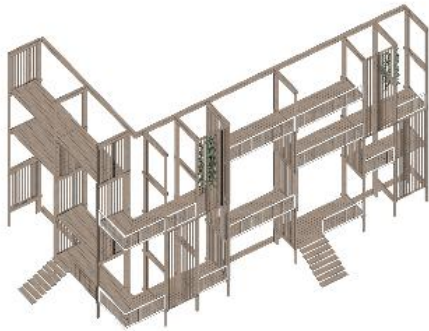

HOW TO...



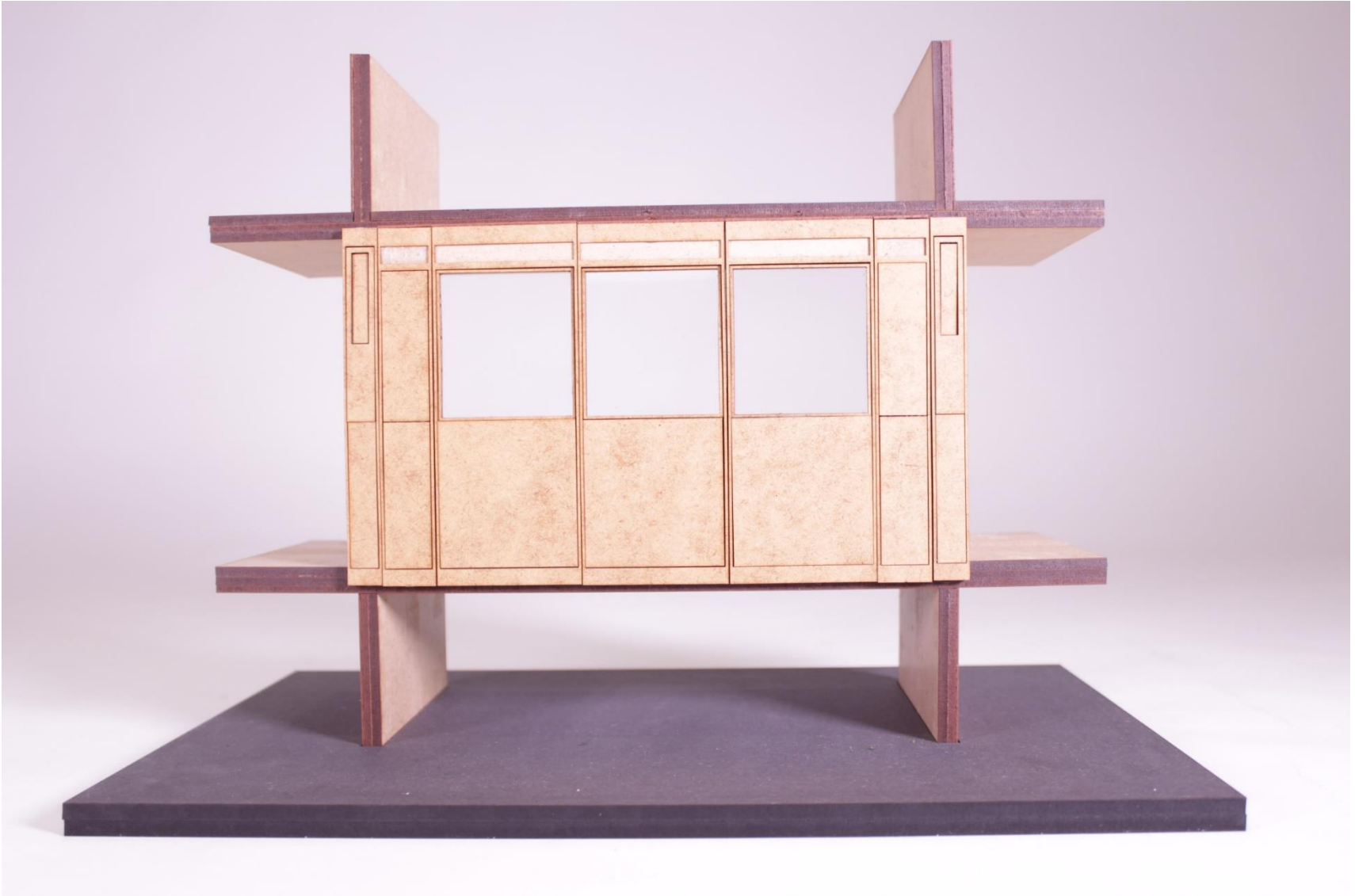

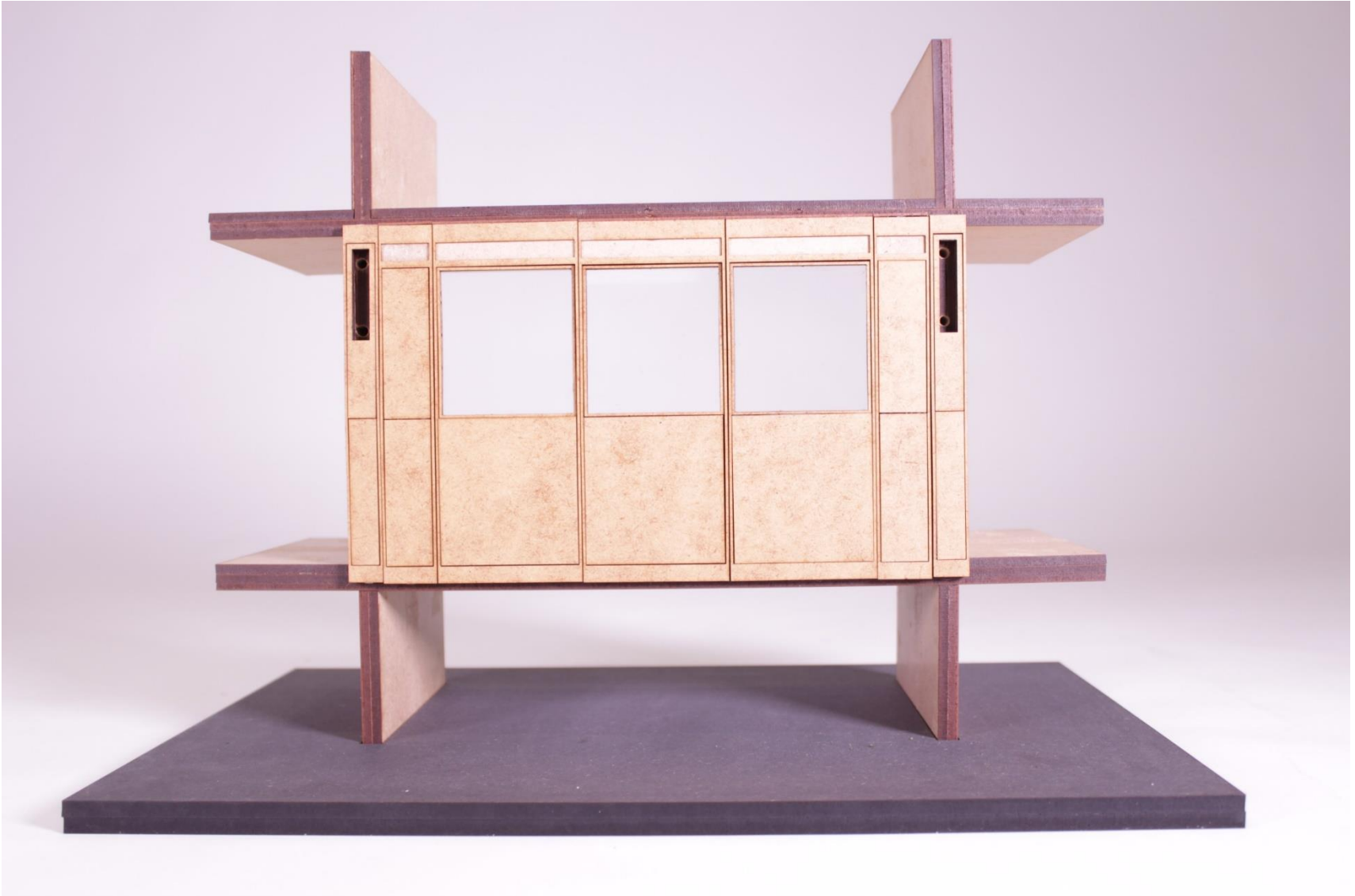



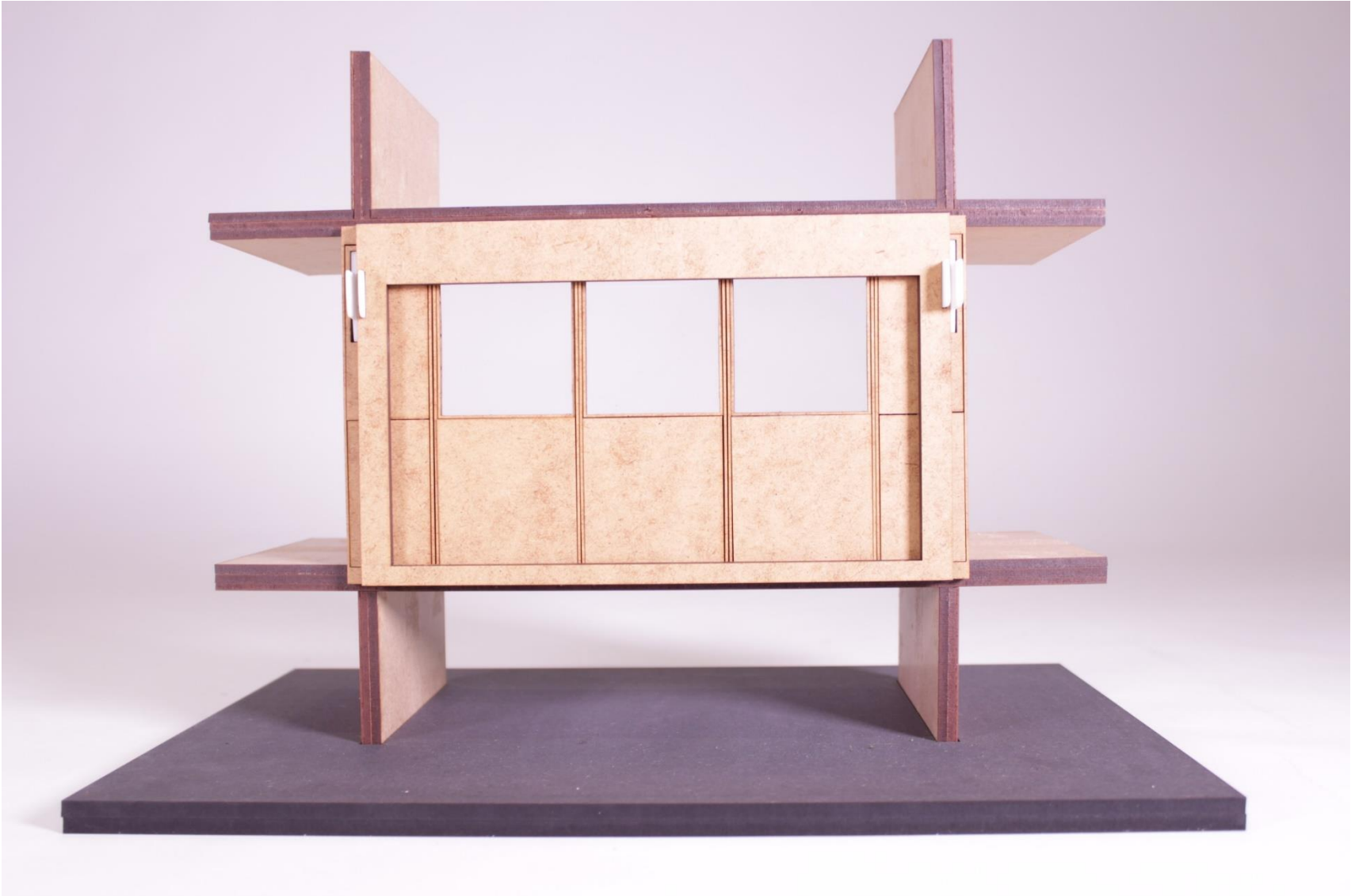



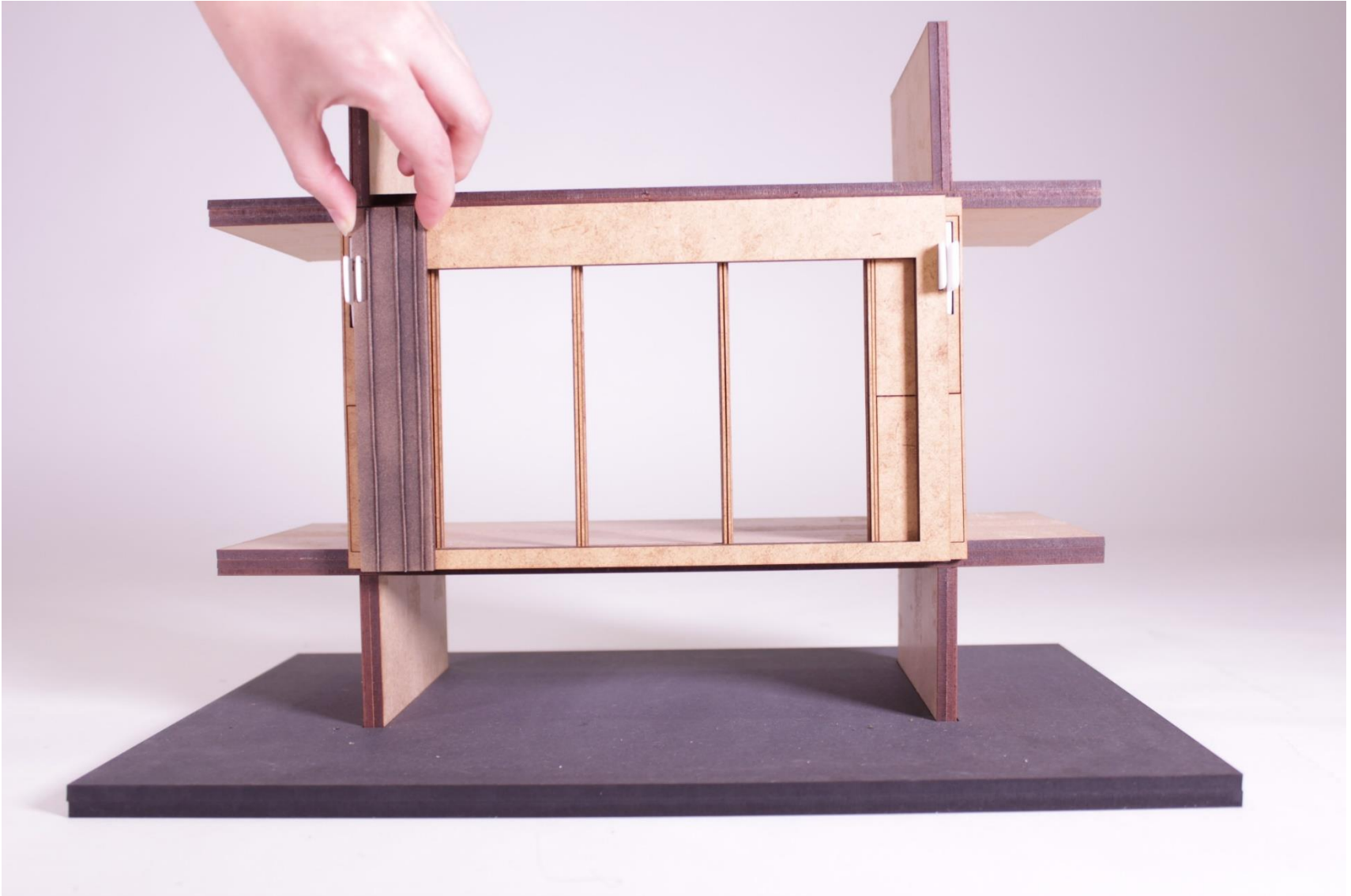

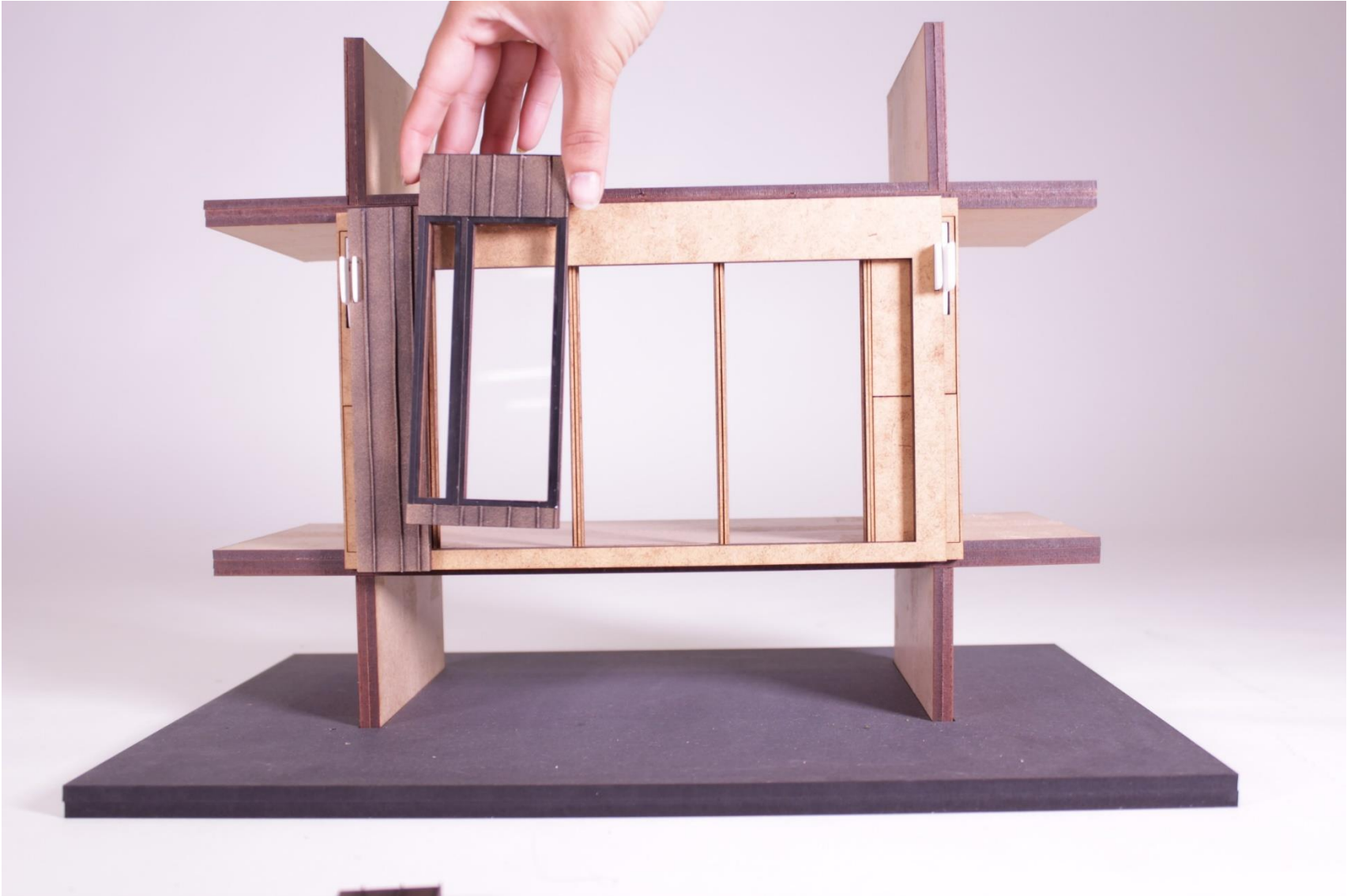

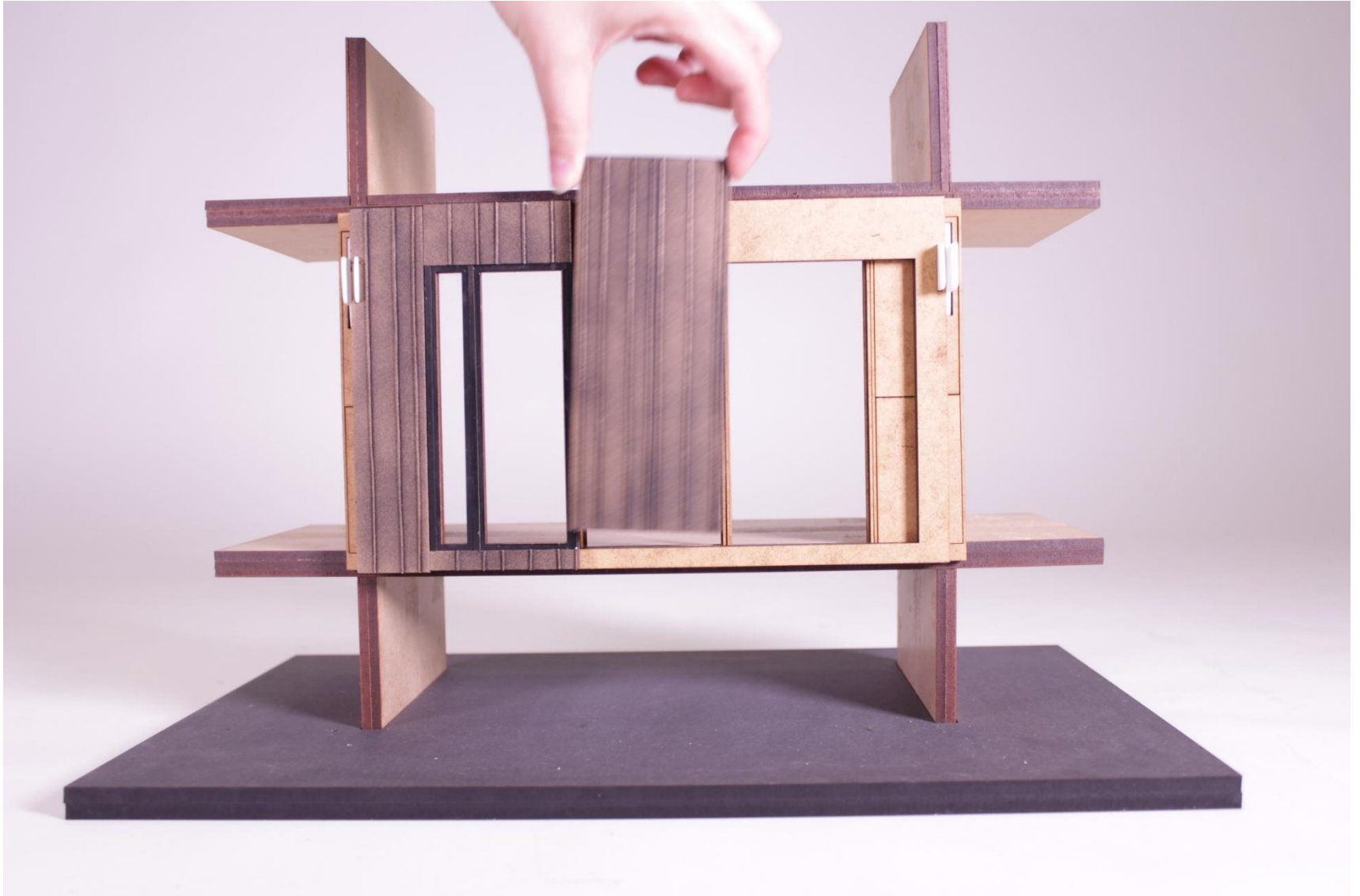











KUNDEREJSEN

FACADEKONFIGURATOR



02 DESIGNGRUNDLAG



06 RESULTAT



REBUS - kunderejse

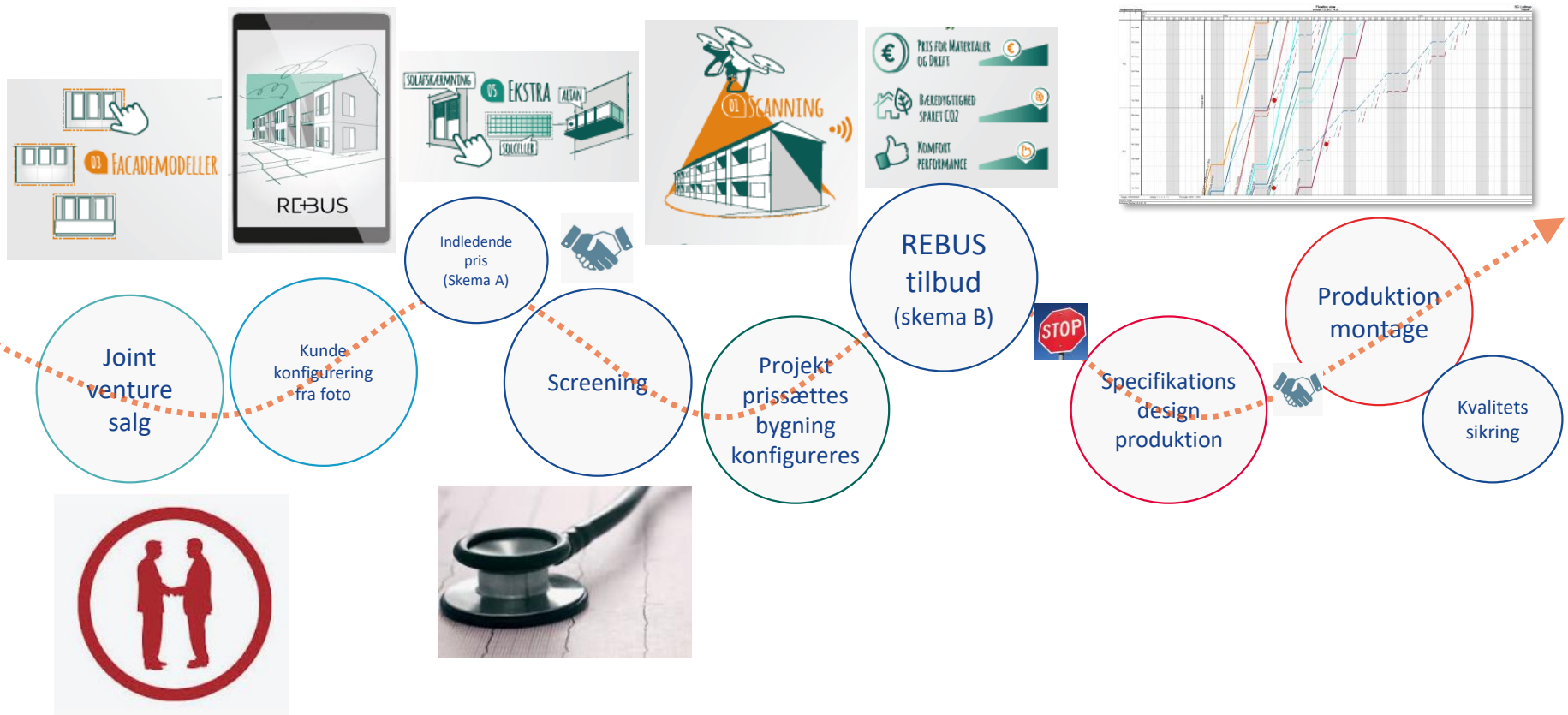

REBUS - kunderejse

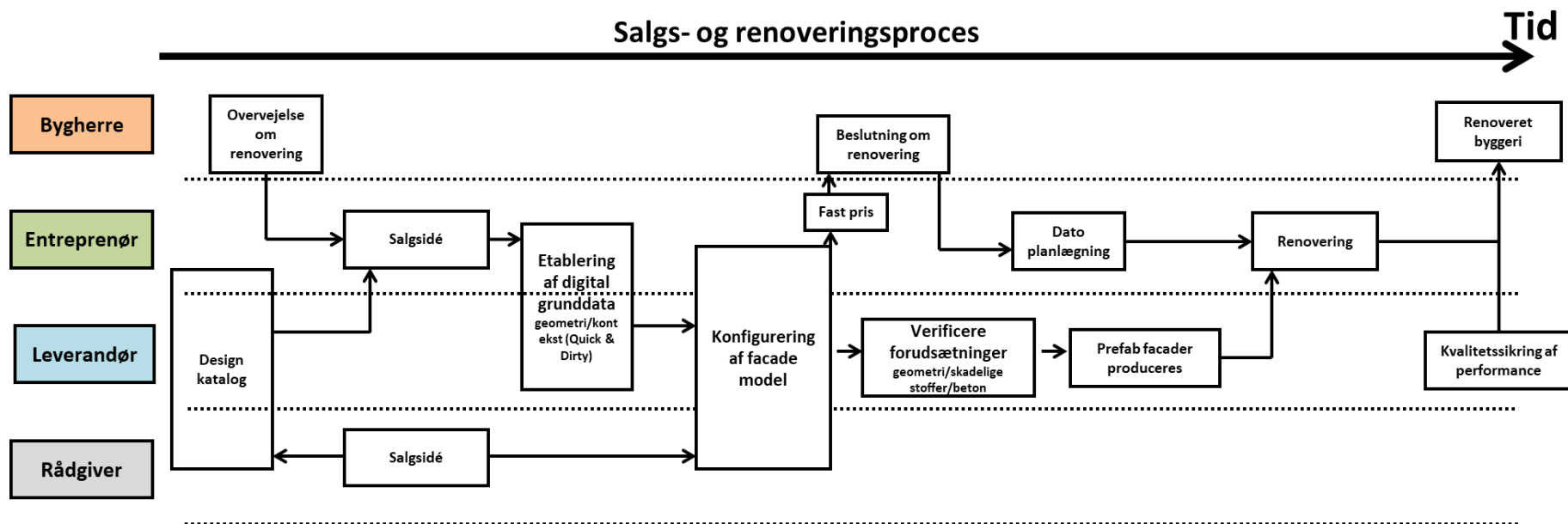

A photograph of a modern, multi-story apartment building with balconies, set against a clear blue sky with a few clouds. The building has a light-colored facade and dark window frames. The balconies are enclosed with glass and have colorful railings in shades of red and blue. A green rectangular overlay is positioned on the left side of the image, containing the text 'RE+BUS' and 'RENOVATING BUILDINGS SUSTAINABLY'.

RE+BUS

RENOVATING BUILDINGS SUSTAINABLY